

NOTES:

- CLEARANCES:
MIN. 5' FROM EDGE OF DRIVEWAY - METERS SHALL BE PLACED OUTSIDE OF DRIVEWAY
MIN. 10' FROM TREES
MIN. 5' FROM OTHER UTILITIES, EXCEPT SEWER AT 10' MIN.
MIN. DEPTH AT RIGHT OF WAY IS 18"
- COMPRESSION FITTINGS SHALL BE U.S. BRASS - NO GALVANIZED OR PLASTIC.
- THE SERVICE LINE SHALL BE CONTINUOUS WITHOUT SPLICES, JOINTS OR COUPLINGS OF ANY KIND BETWEEN THE CORPORATION STOP AND CURB STOP VALVE UNLESS APPROVED BY THE CITY.
- NO DIRECT TAPS SHALL BE ALLOWED.
- METER LOCATION SHALL BE 12" MIN. FROM PROPERTY LINE. LOCATION TO BE CONFIRMED BY CITY.
- SADDLES SHALL BE DUCTILE IRON, STAINLESS STEEL, OR BAND-TYPE WITH I.P. STANDARD TAPPING.
- BALL CORPORATION STOPS FOR USE WITH SADDLES SHALL BE OF BRASS WITH INLET I.P. STANDARD THREAD AND COMPRESSION OUTLET COMPATIBLE WITH CONNECTION PIPING, WITH NO ADAPTERS.
- SERVICE TUBING SHALL BE 1" HDPE (200 PSI RATING, CTS, BLUE) OR 1" TYPE K COPPER TUBING.
- COMPRESSION COUPLING FOR USE IN CONNECTING PLAIN END WATER SERVICE TUBING SHALL BE APPLICABLE FOR THE TYPE OF TUBING BEING COUPLED. COMPRESSION COUPLINGS SHALL HAVE ARMORED GASKETS WHEN DIS-SIMILAR METAL TUBING IS JOINED.
- CORPORATION STOPS AND COUPLINGS SHALL BE OF THE FOLLOWING MANUFACTURER BRANDS AND BE COMPRESSION DESIGN:
MUELLER
McDONALD
FORD
- 3/4" AND 1" WATER METERS SHALL BE PROVIDED BY THE CITY.
- METER SETTERS SHALL BE FORD70 SERIES VBB74-12W-11-44-NL OR APPROVED EQUAL. INSTALLATION OF 3/4" METERS REQUIRES ADAPTORS. ADAPTORS SHALL BE BRASS, FORD A24-NL OR APPROVED EQUAL.
- METER BOXES SHALL BE ARMORCAST A6001419-KO WITH A A6001420TDW-H7 COVER AND 00361020 CAST IRON DROP IN LID, OR APPROVED EQUAL.
- ALL FITTINGS CONNECTING TO METER SETTER SHALL BE GASKETED (FIBER FOR DUAL PURPOSE NUTS, RUBBER FOR BALL VALVE ANGLE STOPS).
- ADJACENT METER BOXES SHALL BE LOCATED SUCH THAT THERE IS A MINIMUM OF 16" SPACE BETWEEN OUTSIDE WALLS.

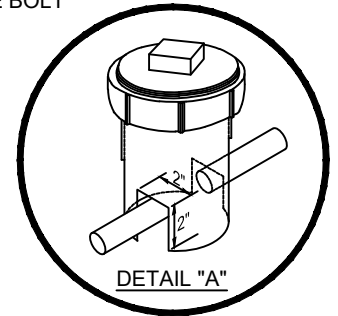

N.T.S.

3/4" AND 1" WATER SERVICE CONNECTION

STANDARD PLAN NO.

KW-010-21

CITY OF KELSO
DEPARTMENT OF
COMMUNITY DEVELOPMENT
& ENGINEERING

CITY ENGINEER APPROVAL: Michael Kardas, P.E.

x *[Signature]*

DATE:

MAY 2021