

**BROOKS NO.37-T**

---

**TRAFFIC COVER AND BOX  
TOUCH AND READ APPLICATION**

ALL DEVELOPMENT  
PROJECTS SHALL HAVE  
REMOTE READ METERS

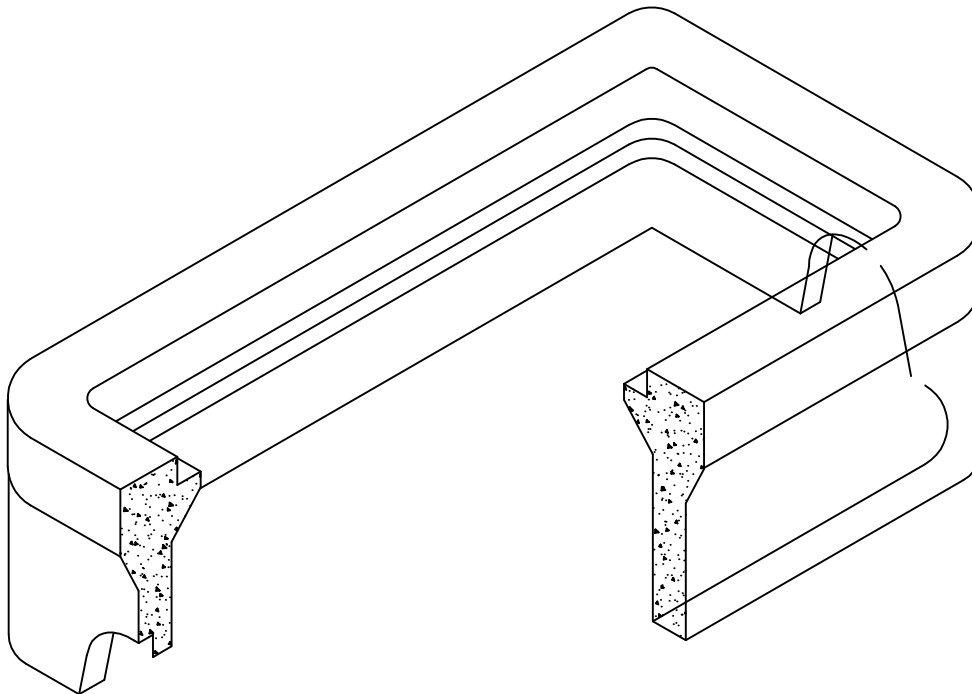
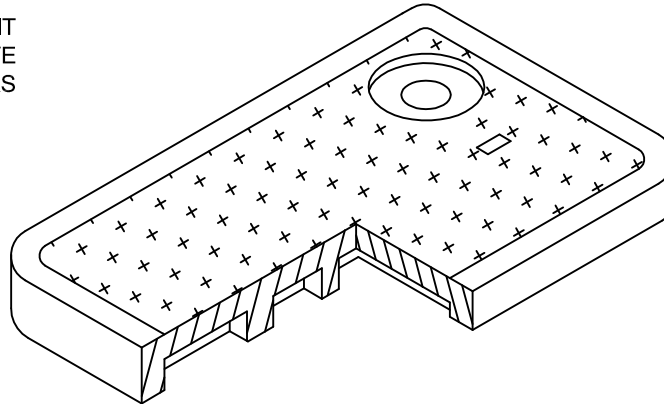

**TOUCH AND READ FOR 3/4" WATER METER BOX**

STANDARD PLAN:  
**W - 100**

DATE: **FEB. 2007**

CITY ENGINEER APPROVAL:

Longview: **C.B.**

Kelso: **S.Z.**