

NOTES:

1. TRENCH GRATE WIDTH SHALL BE 18".
2. TRENCH DRAINS SHALL BE SPACED FOR THE VOLUME OF WATER CONVEYED INTO THE FACILITY, IN ORDER TO MEET FLOW SPREAD CRITERIA AND FULL STORMWATER CAPTURE.
3. TRENCH GRATE SHALL BE A DECORATIVE DESIGN OF IRON OR ALUMINUM AND CONFORM TO ADA STANDARDS.
4. ATTACH TRENCH GRATE PER MANUFACTURER INSTRUCTIONS. USE FRAME SPECIFIED BY MANUFACTURER.

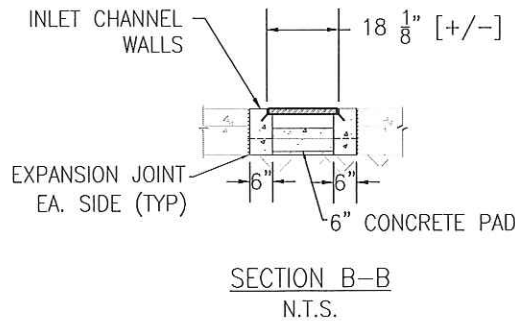
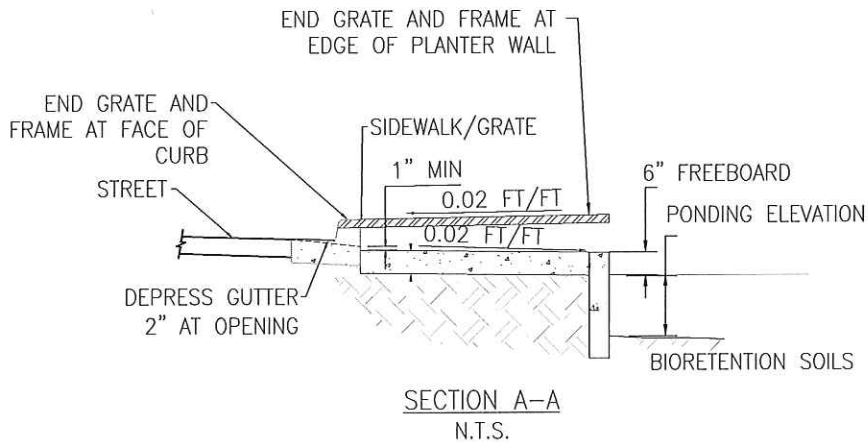

TRENCH DRAIN TO BIORETENTION FACILITY

STANDARD PLAN:
SD-100 LID

DATE: JUNE 2017

CITY ENGINEER APPROVAL: